

SPECIFICATIONS

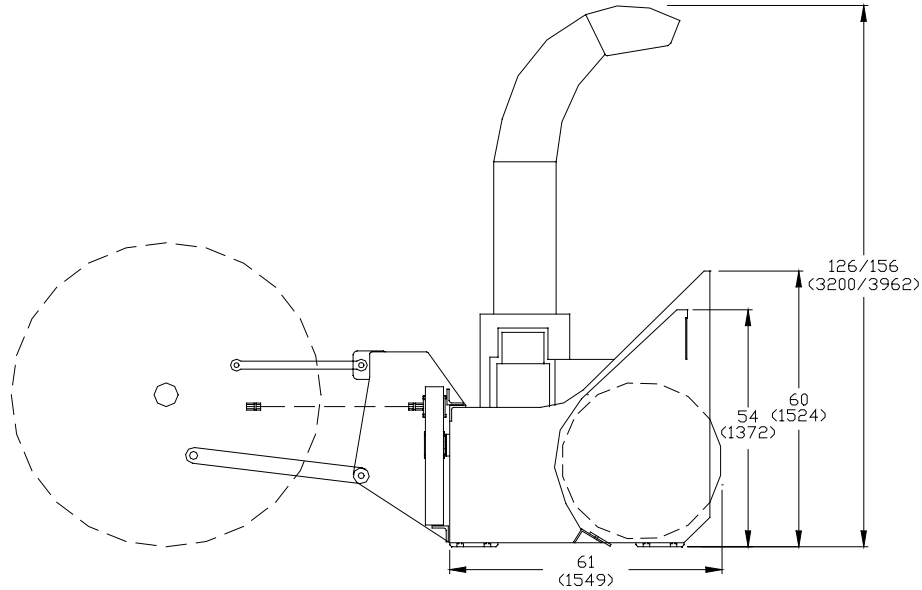

SNOWBLOWER MODEL C-915TR3

PERFORMANCE*

Up to 2750 tons/hour
Casting distance up to 150 ft. (46m)

WEIGHT AND DIMENSIONS

Overall height 126 in.-156 in. (3200-3962 mm)
Overall width 102 in.-110 in. (2591-2794 mm)
Working height 54 in. (1372 mm)
Net weight (approx) 3500 lb. (1588 kg)

DRIVE LINE SYSTEM

Reversing transfer case, fully enclosed oil bath, gears and chain reduction, shear bolt protected

RIBBON AUGER

36 in. (915 mm) diameter, ice cutter flights,
3/8 in. (9.53 mm) thick, 4 in. (102 mm) wide

TRUCK LOADING CHUTE

15 1/2 in. (394 mm) diameter
Rotation 300 °

*Depending on snow conditions

IMPELLER

40in. (1016 mm) diameter, five(5) easily replaceable concave blades

IMPELLER CASING

High tensile steel, replaceable, hydraulic rotation

SHOES/SCRAPER BLADE

Heat treated carbon steel, bolted and replaceable

HYDRAULIC SYSTEM

Carrier hydraulic system for truck loading chute and impeller casing

OPTIONAL EQUIPMENT

Hydraulically extensible chute: 30 in. (762 mm)
Overall width 110 in. (2794 mm)
Rubber scraper blade

CARRIER REQUIREMENT

140 to 275 hp farm tractor

04-04

At CONTANT Inc., our policy is to meet the highest quality standards. In order to improve our products, changes in design or alterations might occur, it will in no way alter quality or efficiency of our equipment.

CONTANT INC.

6310 Boul. Des Mille-îles
Laval, Qc. H7B-1E5
Tel : (450) 666-6368 or 1-800-CONTANT
Fax : (450) 666-0626
WWW.CONTANTLAVAL.COM

Distributed by :