

SPECIFICATIONS

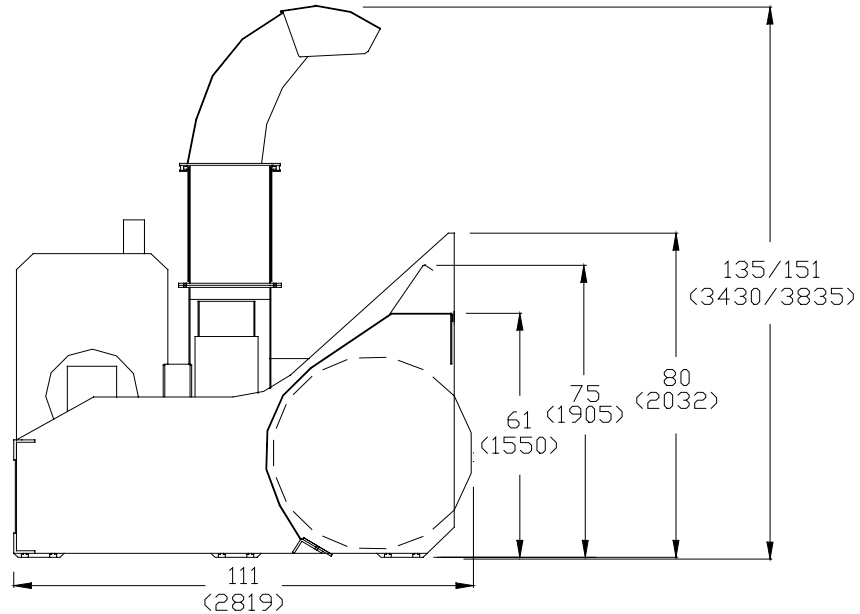

SNOWBLOWER MODEL C-1230D

PERFORMANCE*

Up to 5500 tons/hour
Casting distance up to 180 ft. (55m)

WEIGHT AND DIMENSIONS

Overall height 135 in.-151 in. (3430-3835 mm)
Overall width 112 in. (2845 mm)
Working height 61 in.-75 in. (1550-1905 mm)
Net weight (approx) 13,000 lb. (5897 kg)

ENGINE

From 400 hp (300 kw) to 600 hp (450 kw) electronic
Dry type air cleaner, muffler

DRIVE LINE SYSTEM

Automatic clutch system, fully enclosed oil bath, gears
and chain reduction, shear bolt protected

RIBBON AUGER

48 in. (1220 mm) diameter, flights 1/2 in. (12.7 mm)
thick, 5 in. (127 mm) wide

TRUCK LOADING CHUTE

20 in. (508 mm) diameter
Rotation 300 °

*Depending on snow conditions

IMPELLER

48in. (1220 mm) diameter, five(5) easily replaceable
concave blades

IMPELLER CASING

High tensile steel, replaceable, hydraulic rotation

SHOES/SCRAPER BLADE

Heat treated carbon steel, bolted and replaceable

HYDRAULIC SYSTEM

Engine driven pump, electric solenoid valves

INSTRUMENT PANEL

Detachable including: tachometer, hourmeter,
voltmeter, oil pressure, water temperature, and fuel
level gauges

OPTIONAL EQUIPMENT

Hydraulically extensible chute: 16 in. (407 mm)
Rubber scraper blade

CARRIER REQUIREMENT

A front end wheel loader 3.25 cubic yards
(2.5 cubic meters) minimum capacity

04-04

At CONTANT Inc., our policy is to meet the highest quality standards. In order to improve our products, changes in design or alterations might occur, it will in no way alter quality or efficiency of our equipment.

CONTANT INC.

6310 Boul. Des Mille-îles
Laval, Qc. H7B-1E5
Tel : (450) 666-6368 or 1-800-CONTANT
Fax : (450) 666-0626
WWW.CONTANTLAVAL.COM

Distributed by :